

快速安装说明

三相机系列

⚠ 注意事项： 所有紧固件请务必锁紧，否则会有进水风险，因此造成的机器故障将不予保修。

A

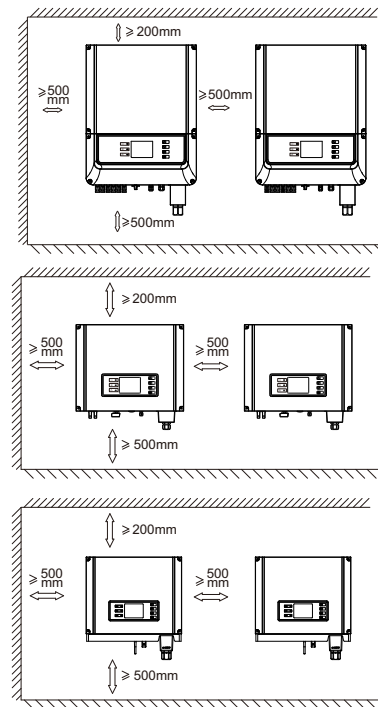

B

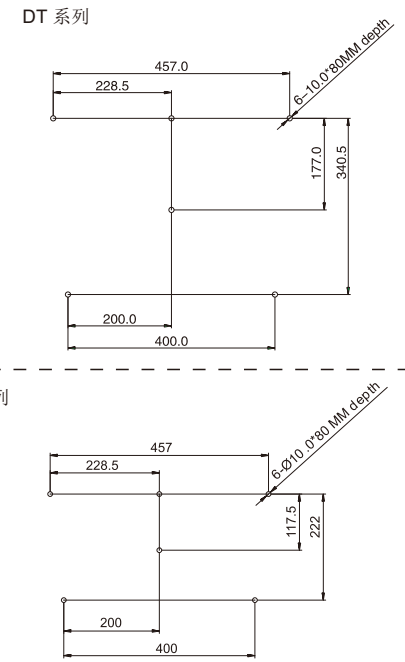

C

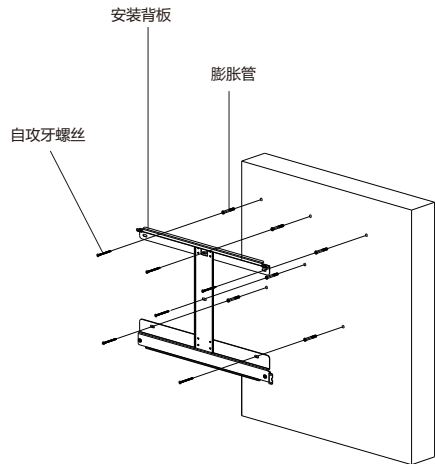

背板固定

D

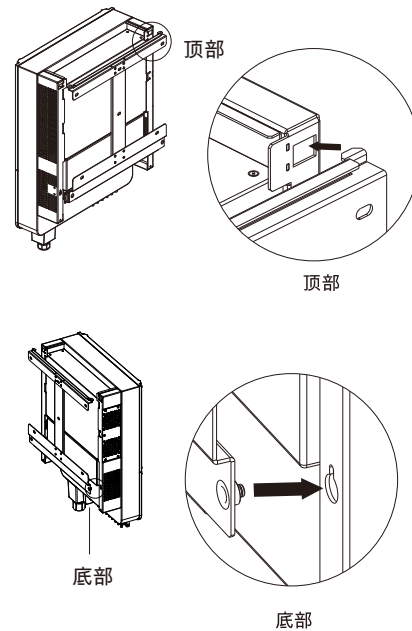

机器安装

E

标准连接

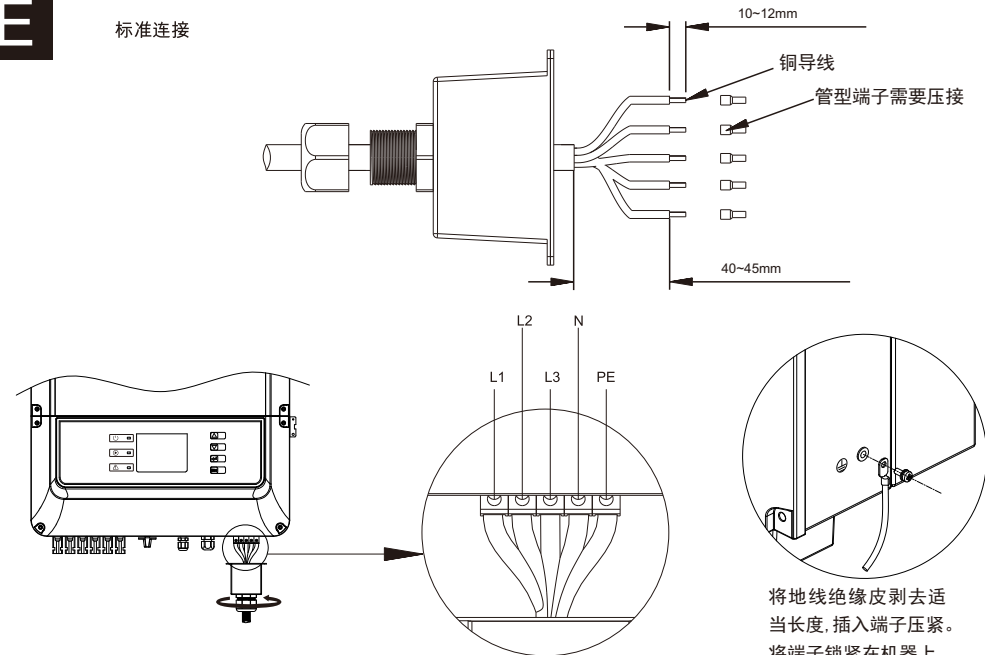

AC 接线和组装

将地线绝缘皮剥去适当长度，插入端子压紧。将端子锁紧在机器上。最后在连接处涂抹硅胶进行防腐保护。

F

SUNCLIX 系列

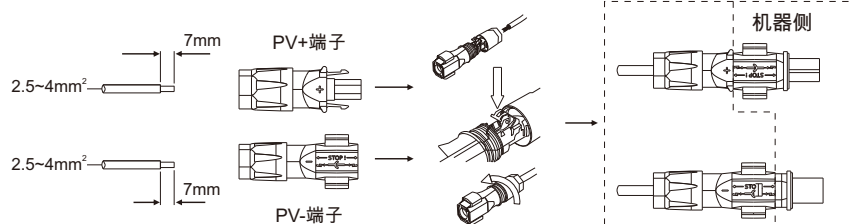

AMPHENOL/MC4 系列

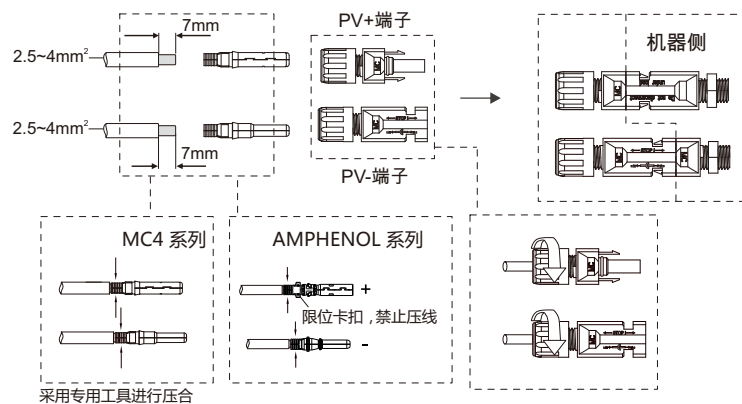

DC 接线和组装

*DC线需要使用专用PV线(建议用4mm²的PV1-F线)

G

DT系列&SDT15KW

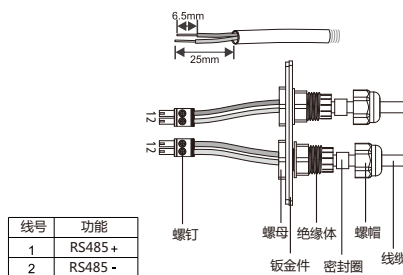
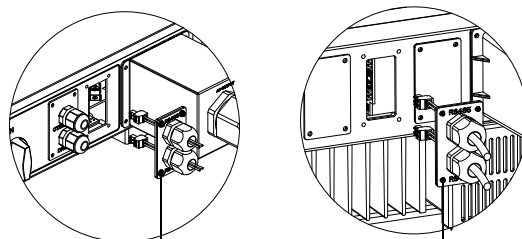

| 线号 | 功能 |
|----|--------|
| 1 | RS485+ |
| 2 | RS485- |

SDT5~10KW

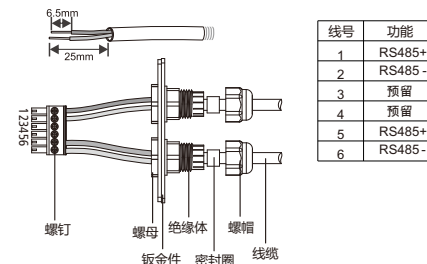
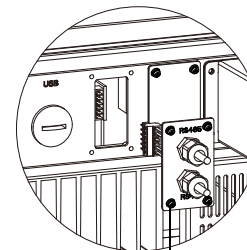

RS485插头接线

H

DT 系列

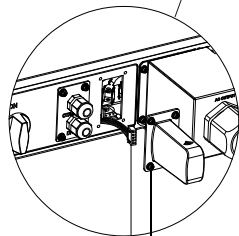
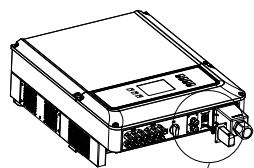

SDT 5~10KW

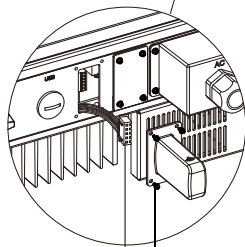
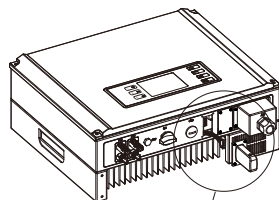

SDT 15KW

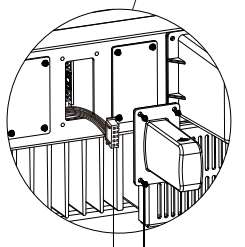
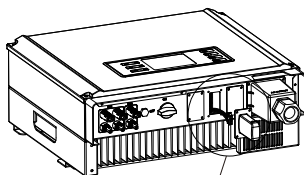

WiFi /GPRS组装

*WiFi/GPRS模块必安装

I

逆变器、电表与电网连接示意图

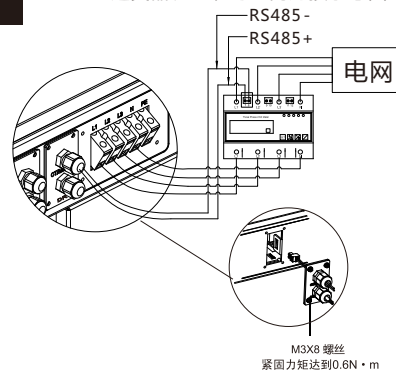

| 线号 | 功能 |
|----|--------|
| 1 | RS485+ |
| 2 | RS485- |
| 3 | 预留 |
| 4 | 预留 |
| 5 | 预留 |
| 6 | 预留 |
| 7 | 预留 |
| 8 | 预留 |

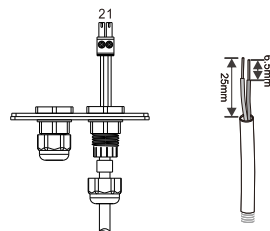

功率限制设备组装

J

设置时间

*请参照下面框图提示, 结合逆变器显示屏内容, 通过按键设置时间

